

**Food Processor  
 Stainless Steel Cutter Mixer - 11.5 LT - 2  
 Speeds with Microtoothed Blade, Bowl  
 and Scraper**

ITEM # \_\_\_\_\_

MODEL # \_\_\_\_\_

NAME # \_\_\_\_\_

SIS # \_\_\_\_\_

AIA # \_\_\_\_\_



600084 (K120S2)

\* NOT TRANSLATED \*

### Main Features

- Productivity suitable for 100-200 meals per service.
- Food processor allows fast liquidizing, mixing, mincing, chopping and pastry-making.
- Delivered with:
  - 11.5 liter stainless steel bowl with max liquid level indication to avoid spillage
  - micro toothed perforated blade
  - scraper
- Angled perforated knives and conical base of the bowl ensure consistent mixing.
- Lid with central opening to add ingredients in mid-cycle.
- Base fixed cover for a better handling.
- Cover metal frame to ensure seal water tightness to avoid leakage.
- All parts in contact with food are removable without tools and completely dismantable.
- Pulse function for coarse chopping.

### Construction

- 304 AISI stainless steel bowl with leak resistant spout and handles, easy to manage.
- Scraper with SS handle, easy to dismount.
- 2 speeds: 1500 and 3000 rpm.
- Power: 2200 watts.
- IP65 touch button control panel.
- Cover handle with double safety locking system.
- Transparent BPA free cover incorporates a magnetic safety system which stops the machine if lid is not properly closed.
- A safety device requires to press the start button to restart the machine after a power cut.
- Asynchronous silent industrial motor for heavy duty and longer life.

### Included Accessories

- 1 of - NOT TRANSLATED - PNC 650059
- 1 of - NOT TRANSLATED - PNC 650060
- 1 of - NOT TRANSLATED - PNC 650073

### Optional Accessories

- - NOT TRANSLATED - PNC 650059
- - NOT TRANSLATED - PNC 650060
- - NOT TRANSLATED - PNC 650073
- Stainless steel mobile stand. Height: 730 mm PNC 653017
- Serrated blade rotor for 11,5 lt cutter mixer PNC 653299
- Serrated blade rotor for meat for 11,5 lt cutter mixer PNC 653538

APPROVAL: \_\_\_\_\_

Front

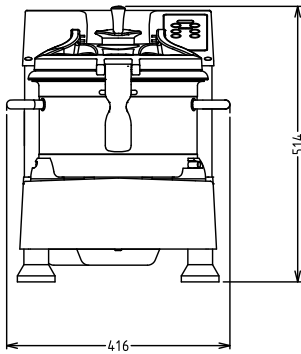

Side

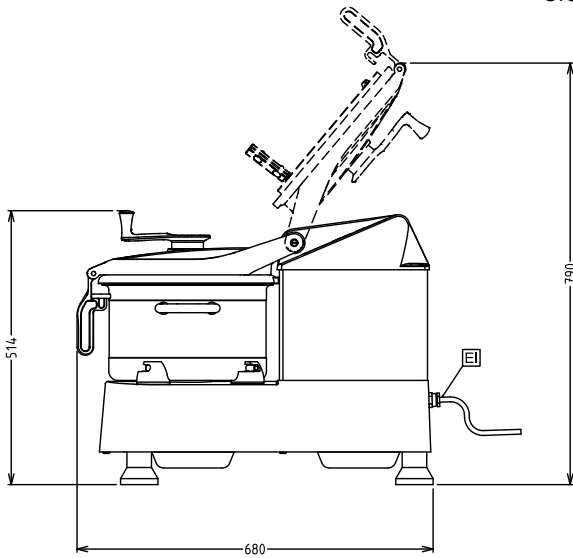

EI = Electrical inlet (power)

Top

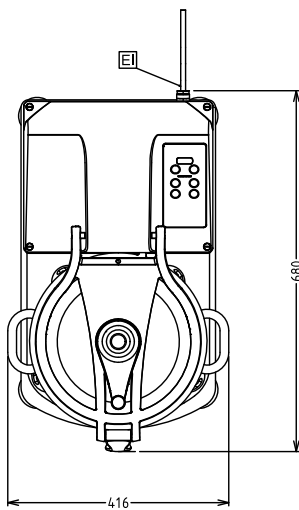



**Electrolux**  
PROFESSIONAL

**Food Processor**  
**Stainless Steel Cutter Mixer - 11.5 LT - 2 Speeds**  
**with Microtoothed Blade, Bowl and Scraper**

### Electric

|                        |                      |
|------------------------|----------------------|
| Supply voltage:        | 380-415 V/3 ph/50 Hz |
| Electrical power max.: | 2.2 kW               |
| Total Watts:           | 2.2 kW               |

### Capacity:

|                      |             |
|----------------------|-------------|
| Performance (up to): | 6 kg/Cycle  |
| Capacity:            | 11.5 litres |

### Key Information:

|                                 |        |
|---------------------------------|--------|
| External dimensions,<br>Width:  | 416 mm |
| External dimensions,<br>Depth:  | 680 mm |
| External dimensions,<br>Height: | 517 mm |
| Shipping weight:                | 68 kg  |



**Food Processor**  
**Stainless Steel Cutter Mixer - 11.5 LT - 2 Speeds with Microtoothed Blade,**  
**Bowl and Scraper**  
The company reserves the right to make modifications to the products  
without prior notice. All information correct at time of printing.

2026.04.21